

NOTE: 1) HYDRO @ 325 PSIG. MIN.

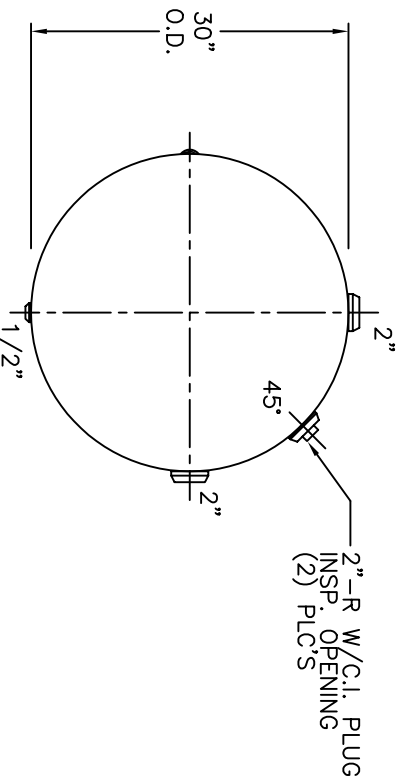

VIEW W/OUT SUPT'S

SHELL / HEADS		.204" MIN. SA-455 2:1 S.E.	
JOGGLE			
.207" SA-455 (.205" MIN.)			
M.A.W.P.	250 PSIG. @ 400 °F		
M.D.M.T.	-20 °F @ 250 PSIG.		
ASME SECTION VIII	DIV. 1, 2001 ADD 2003		
X-RAY:	RT-4 SPOT L.S. NOT G.S.		
GALLONS:	240	WT.	542 LBS.
SERIAL NO.			
INSIDE: UNPAINTED		30-HC-240-W	
OUTSIDE: PRIME		REV. 5-19-04	
CAD-"B" SIZE UNDER "STD"-SERIES		DATE: 9-2-80	
BY: J.G.		FOR: HANSON STANDARD	
SCALE: 1"=12"		HORIZ. AIR TANK	
ROY E. HANSON JR. MFG.			
1924 COMPTON AVE.			
LOS ANGELES, CA 90011			