

3"R W/LG. PILOT  
(3) PLC'S

2" B. W/C.I. PLUG  
INSPECTION OPENING  
(2) PLC'S

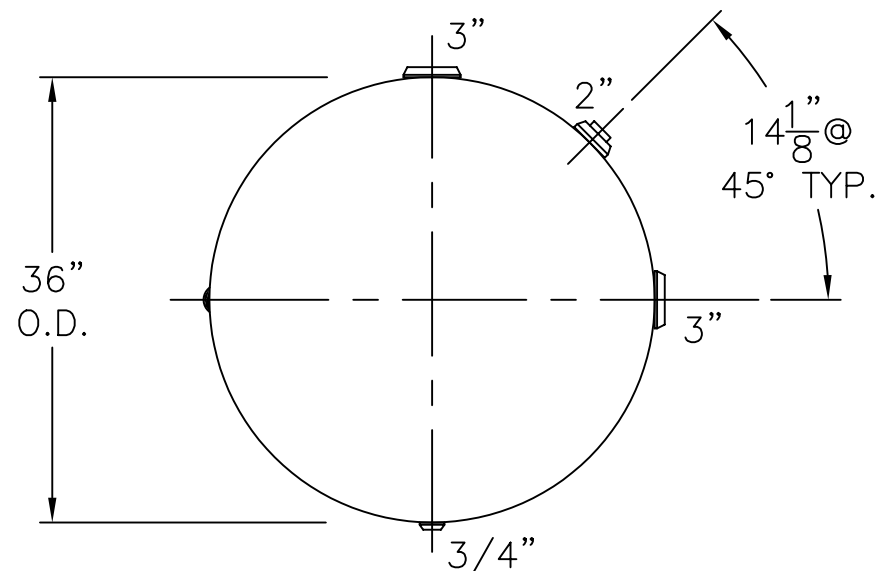
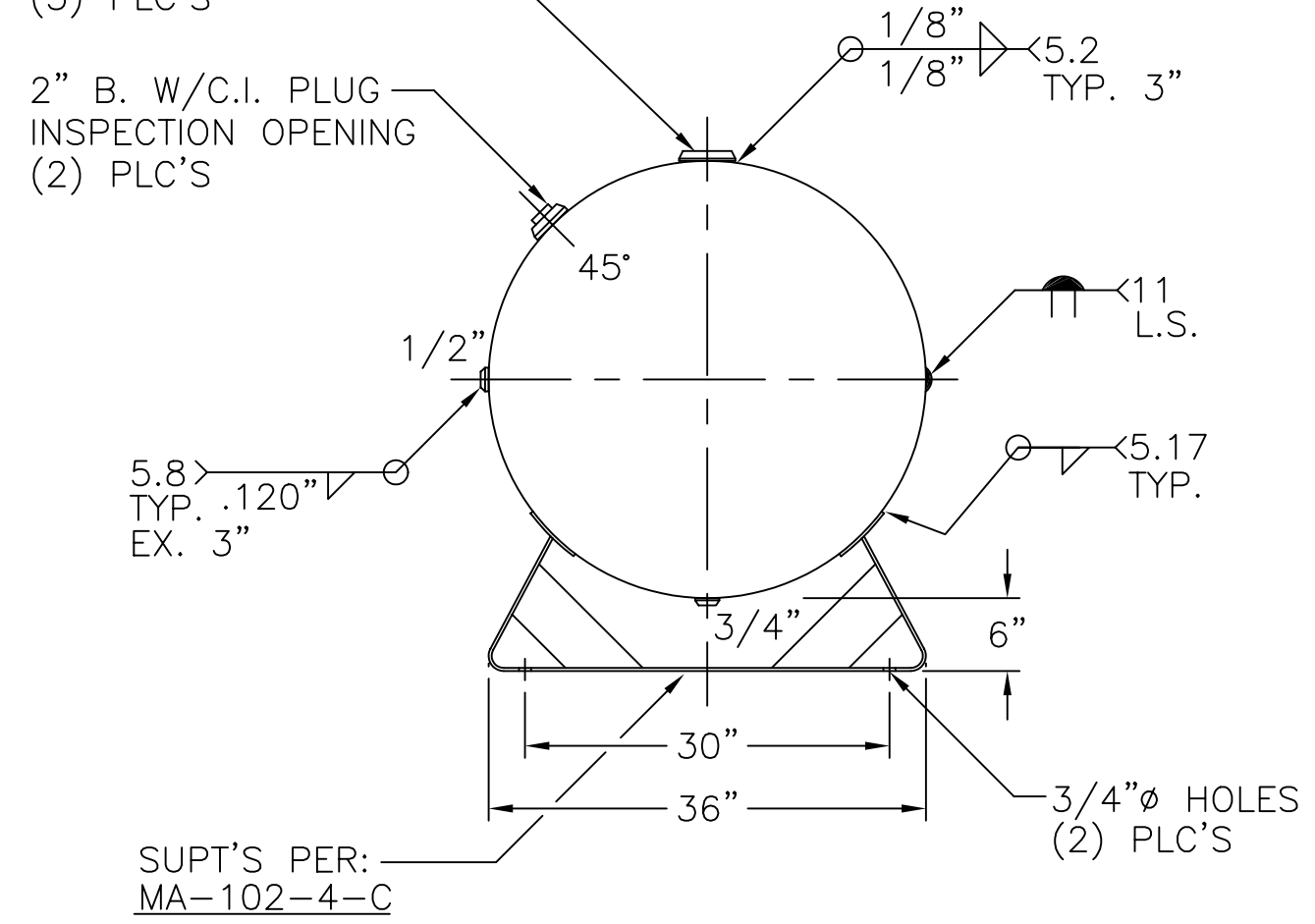

VIEW W/OUT TOP SUPT'S

NOTE: 1) HYDRO @ 325 PSIG. MIN.

HEADS	.210" SA-455 2:1 S.E.	36-HC-500-W	REV. 11-18-02
	JOGGLE - .249" OFFSET		DATE: 9-5-80
SHELL	.250" SA-455	FOR: HANSON STANDARD	
		HORIZ. AIR TANK	
		INSIDE: UNPAINTED	
M.A.W.P. 250 PSIG. @ 400 °F		OUTSIDE: PRIME	
M.D.M.T. -20 °F @ 250 PSIG.		CAD-"B" SIZE UNDER "STD"-SERIES	
ASME SECTION VIII DIV. 1, 2001		BY: J.G.   SCALE: 3/4"=12"	
X-RAY: RT-4 SPOT L.S. & HEADS G.S.		<b>ROY E. HANSON JR. MFG.</b>	
GALLONS: 500   WT. 1060 LBS.			
SERIAL NO.		1924 COMPTON AVE. LOS ANGELES, CA 90011	