

VIEW W/OUT SUPT'S

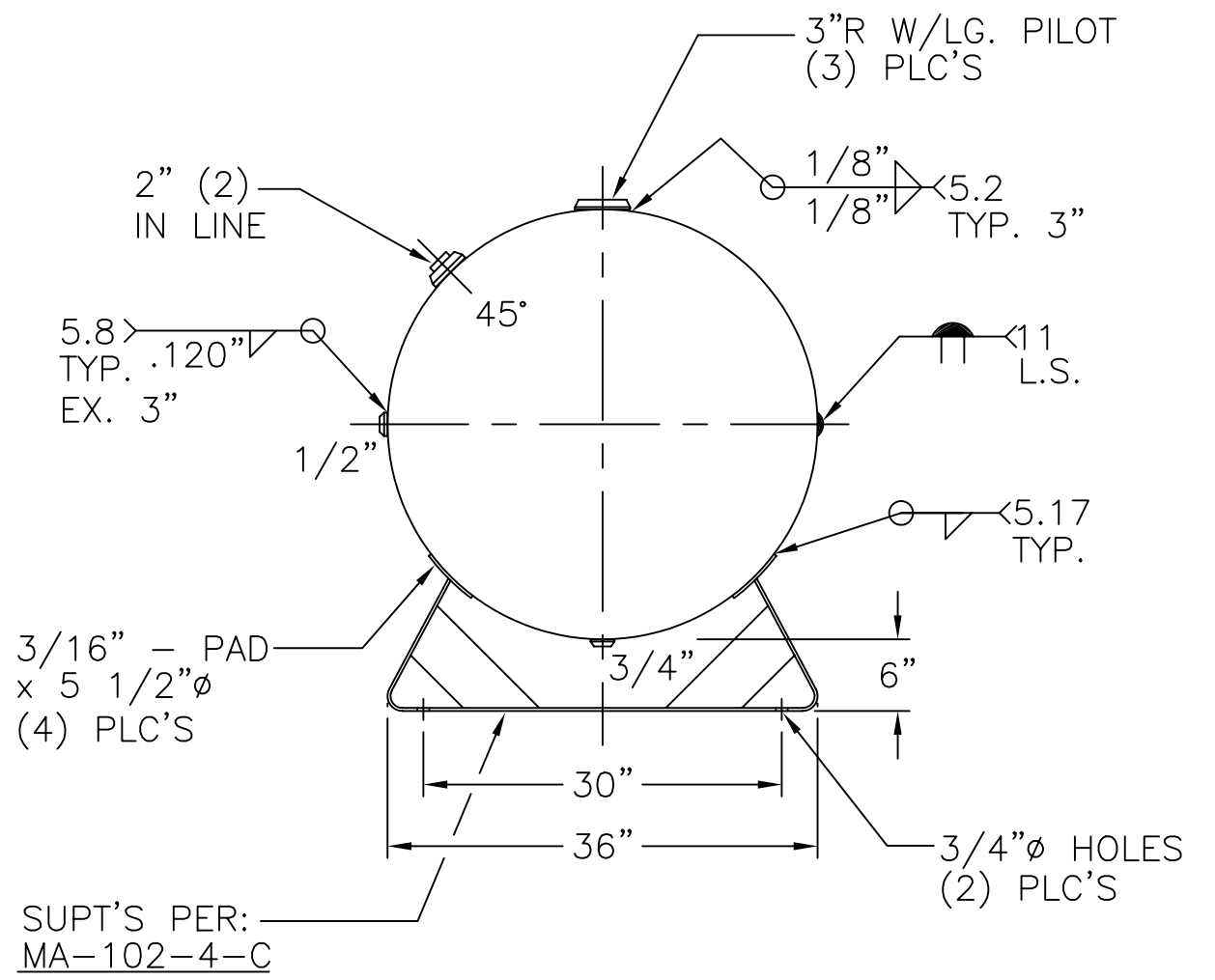

NOTE: 1) HYDRO @ 215 PSIG. MIN.

HEADS	.182" SA-455 2:1 S.E.	36-HM-400-W	REV.
	JOGGLE		DATE: 2-3-03
SHELL	.166" SA-414-G	FOR: HANSON STANDARD	
		HORIZ. AIR TANK	
M.A.W.P. 165 PSIG. @ 400 °F		INSIDE: UNPAINTED	
M.D.M.T. -20 °F @ 165 PSIG.		OUTSIDE: PRIME	
ASME SECTION VIII DIV. 1, 2001 ADD 2002		CAD-"B" SIZE UNDER "STD"-SERIES	
X-RAY: RT-4 SPOT L.S. ONLY		BY: E.S.	SCALE: 3/4"=12"
GALLONS: 400		WT. 643 LBS.	
SERIAL NO.		ROY E. HANSON JR. MFG.	
		1924 COMPTON AVE. LOS ANGELES, CA 90011	